



TT – Modellbahnprojekt 2010 / 2018

Eingleisig Hauptbahn mit Fernverkehr und
eine abzweigenden eingleisigen Nebenbahn



Epoche: IV
Zeitraum: 1980 – 1989 (1990)
Landschaft: Mittelgebirgslandschaft
Stromsystem: 2 Stromkreise getrennt
umschaltbar Digital / Analog

Analog: 2 Fahrregler PIKO 55003
0-12 V DC, 450 mA



Digital: Roco z21 START



Rohbau (Unterbau)

Baubeginn: 22: Januar 2018

Bauende:

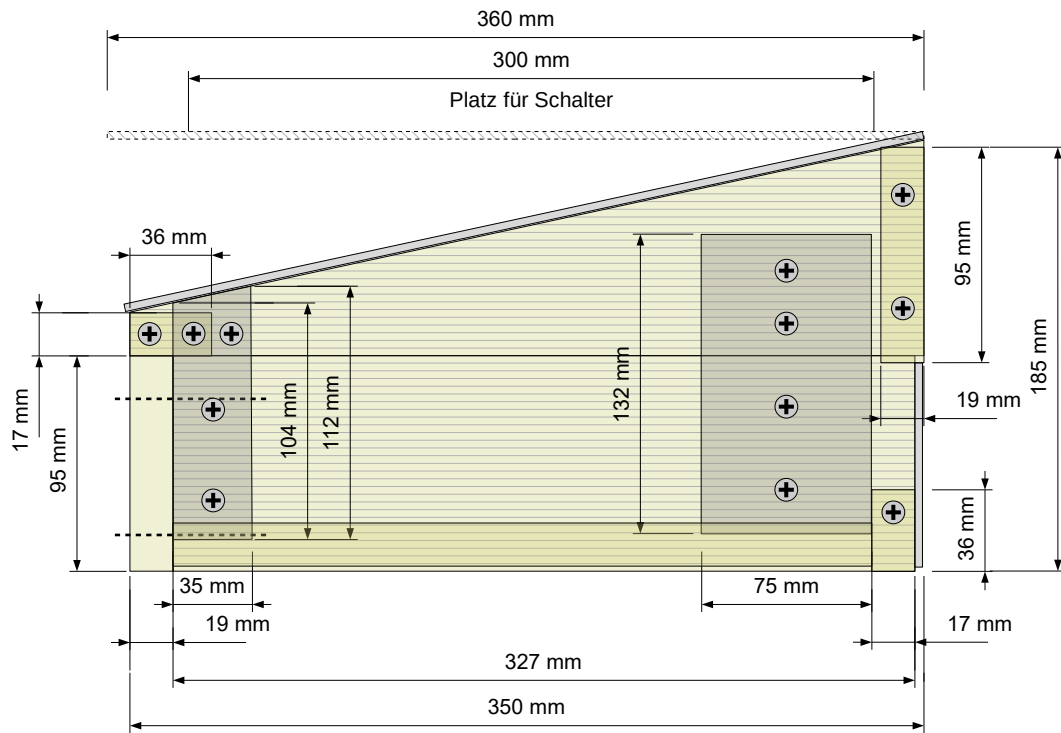

Rechte Seite

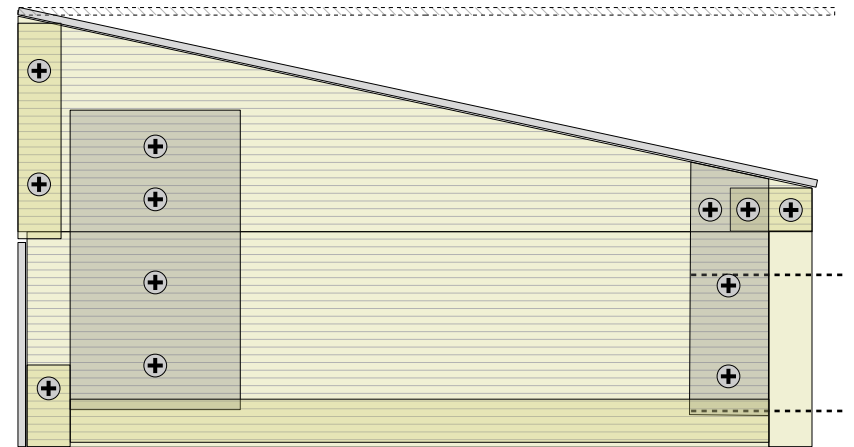

Linke Seite

<p>Projekt</p>	Projekt TT-Modelleisenbahn	
	Name Stellpult Seite 2	
	Grundmaße:	Gesamt 780 mm x 350 mm Höhe 110 x 185 mm
	Bemerkung Stellpult Linke und rechte Seite	
	Baubeginn 09. März 2018	Bauende

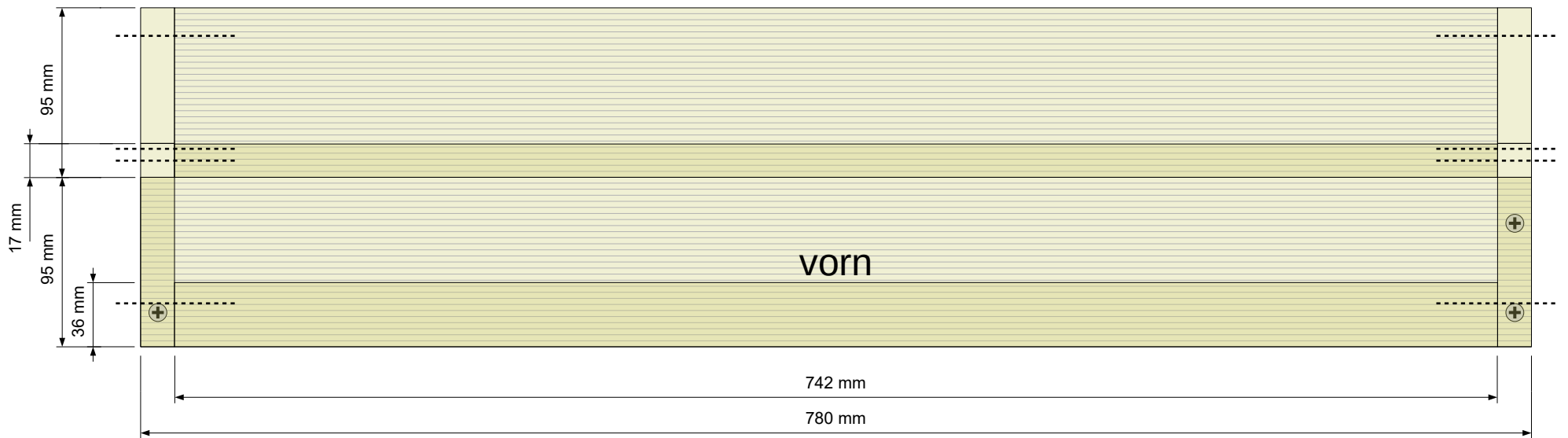
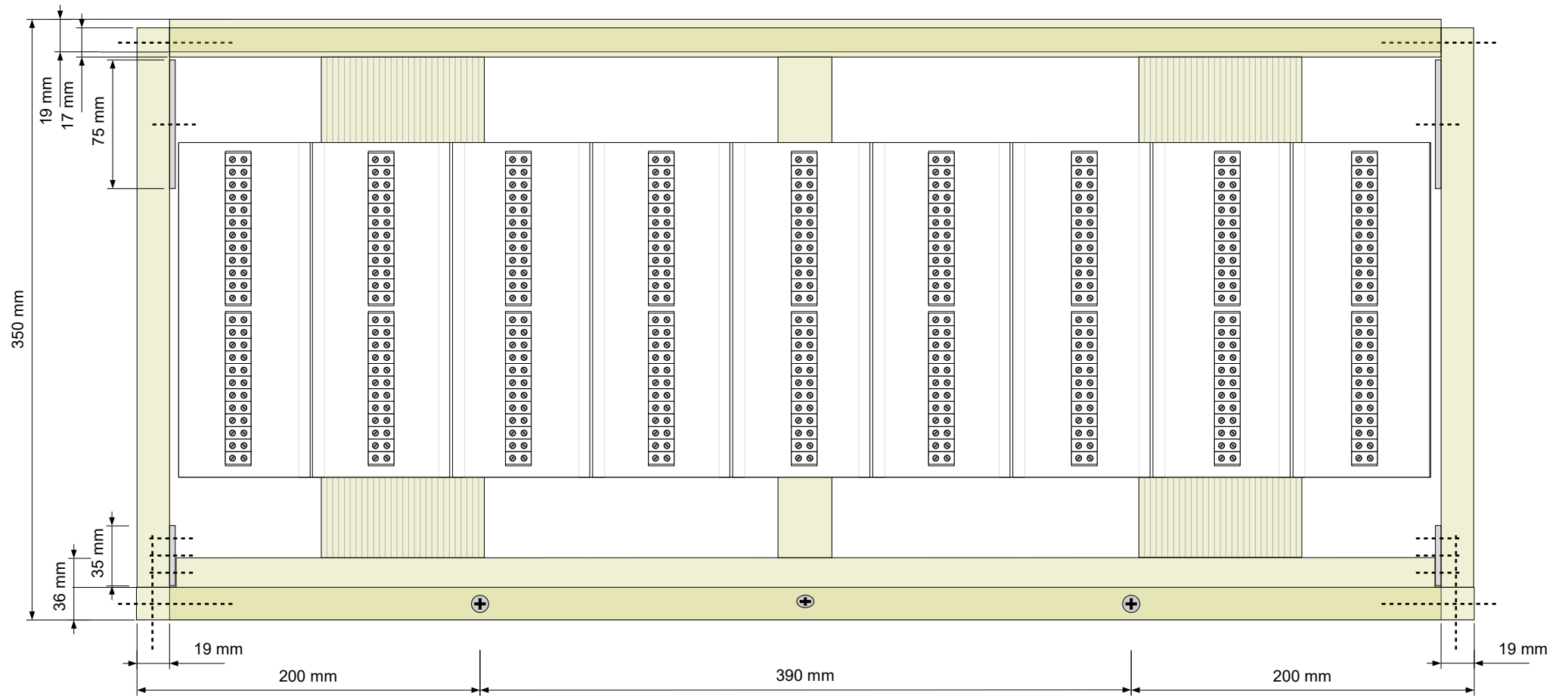

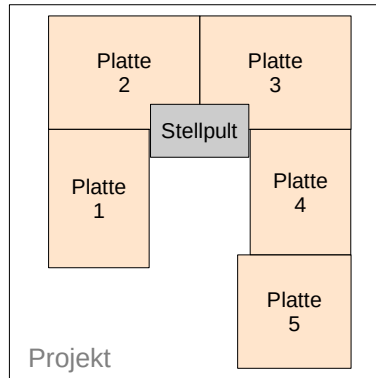
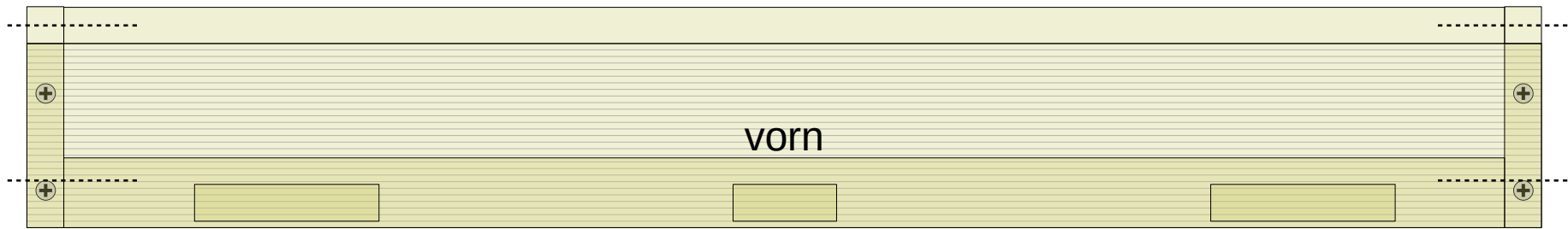

Projekt	TT-Modelleisenbahn	
Name	Stellpult Seite 4	
	Grundmaße:	Gesamt 780 mm x 350 mm Höhe 110 x 185 mm
Bemerkung	Stellpult vorn und hinten	
Baubeginn	09. März 2018	Bauende 09. März 2018

Projekt

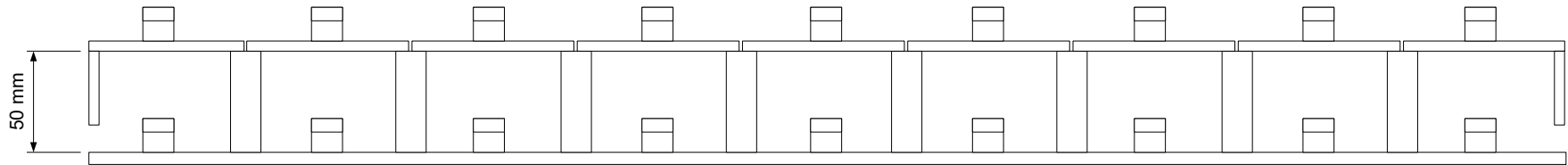
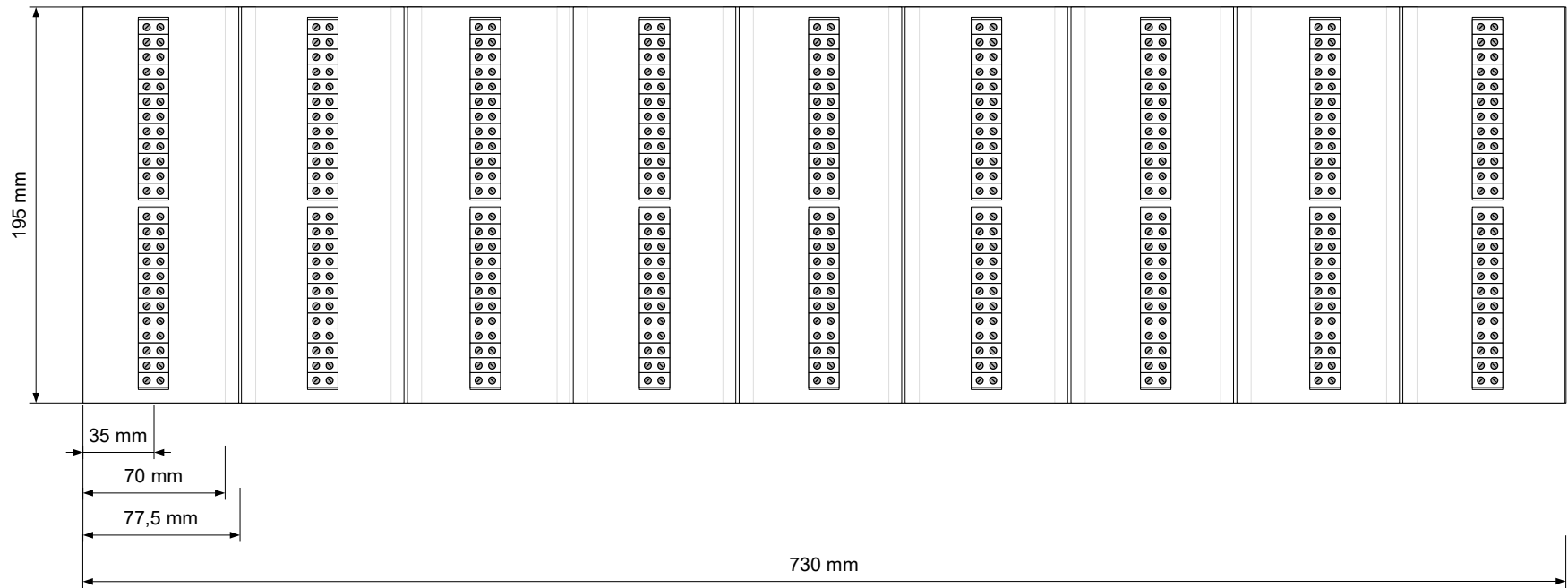

	Projekt TT-Modelleisenbahn	
	Name Stellpult Seite 5	
	Grundmaße: Gesamt 780 mm x 350 mm Höhe 110 x 185 mm	
	Bemerkung Stellpult Anschlüsse (432 Anschlüsse)	
	Baubeginn 09. März 2018	Bauende 09. März 2018

Projekt

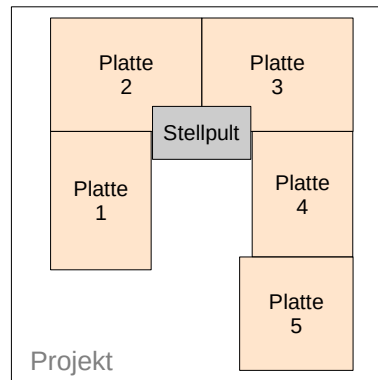
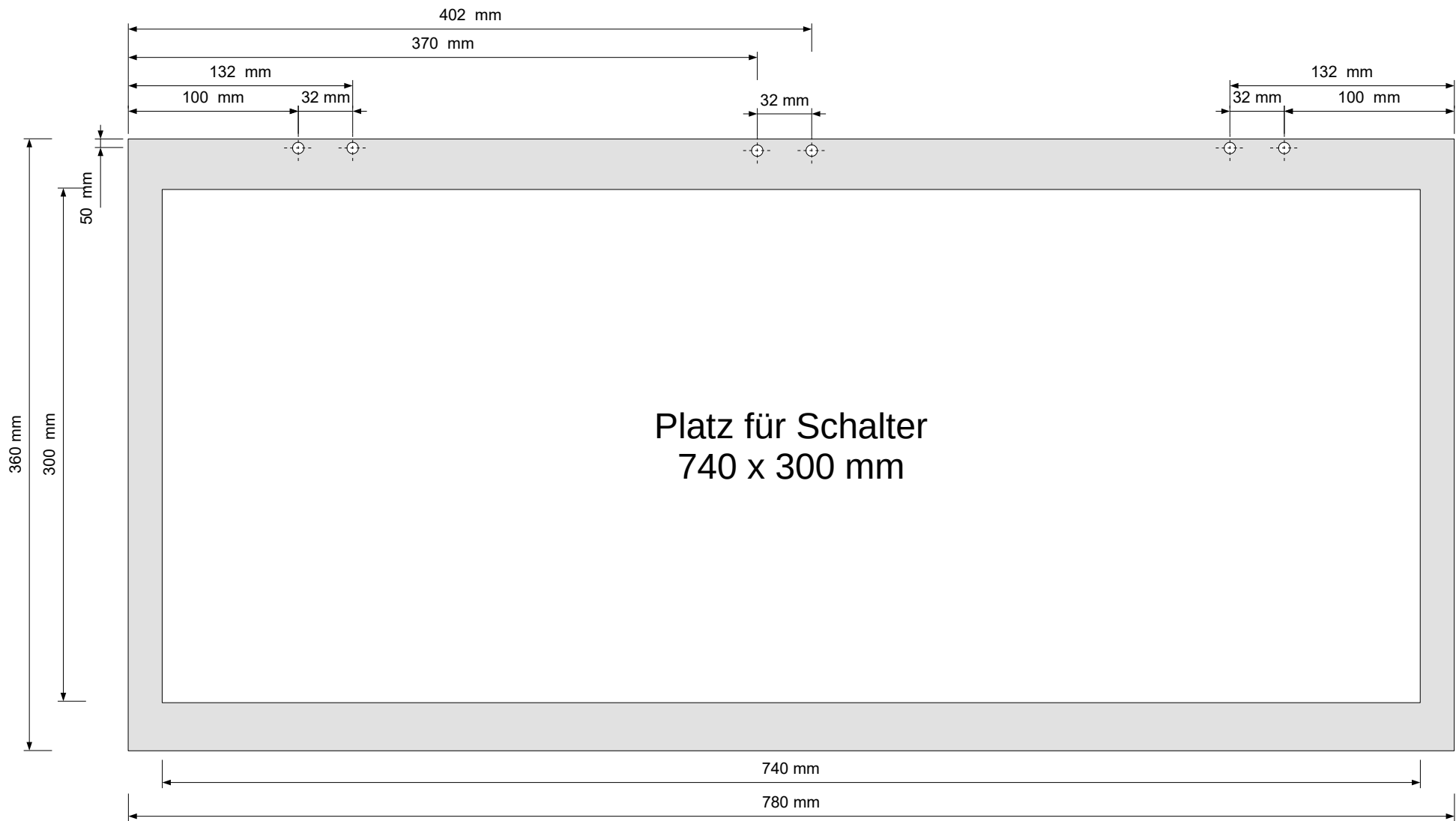

Projekt	TT-Modelleisenbahn	
Name	Stellpult Seite 6	
Bemerkung	Grundmaße:	Gesamt 780 mm x 350 mm
		Höhe 110 x 185 mm
	Gesamtplatz für Stellwerk	
Baubeginn	09. März 2018	Bauende 09. März 2018

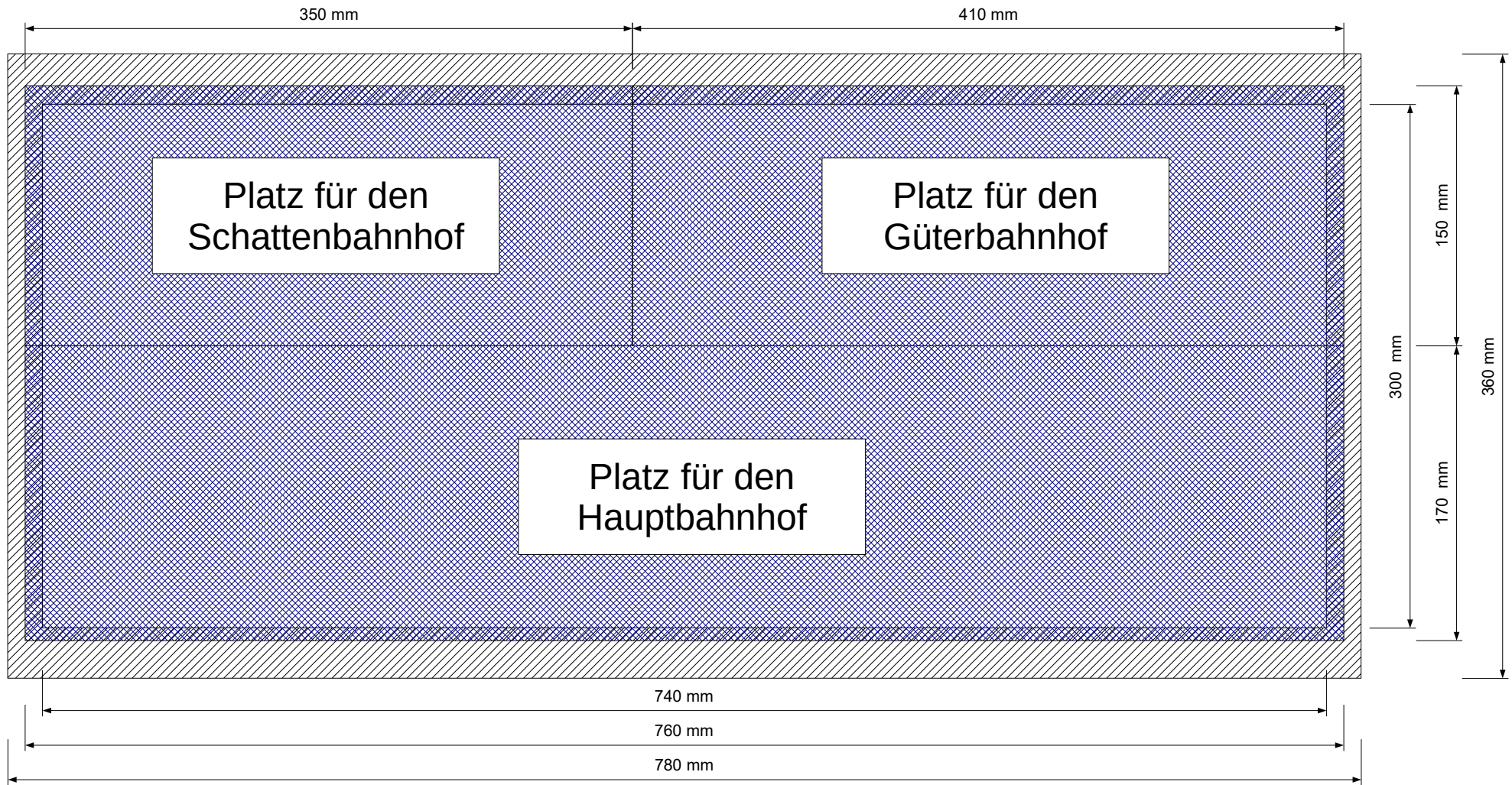

	Projekt	TT-Modelleisenbahn	
	Name	Stellpult Seite 7	
	Grundmaße:	Gesamt	780 mm x 350 mm
	Höhe	110 x 185 mm	
	Bemerkung	Platzaufteilung	
Baubeginn	09. März 2018	Bauende	09. März 2018

Stellpult

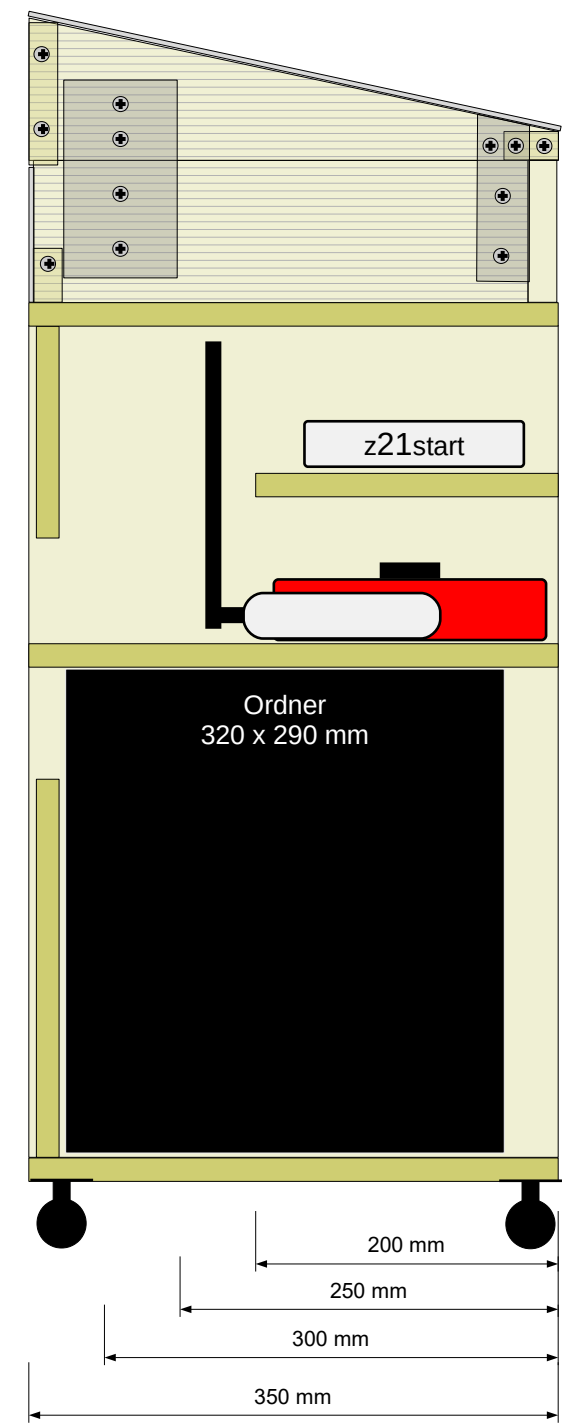
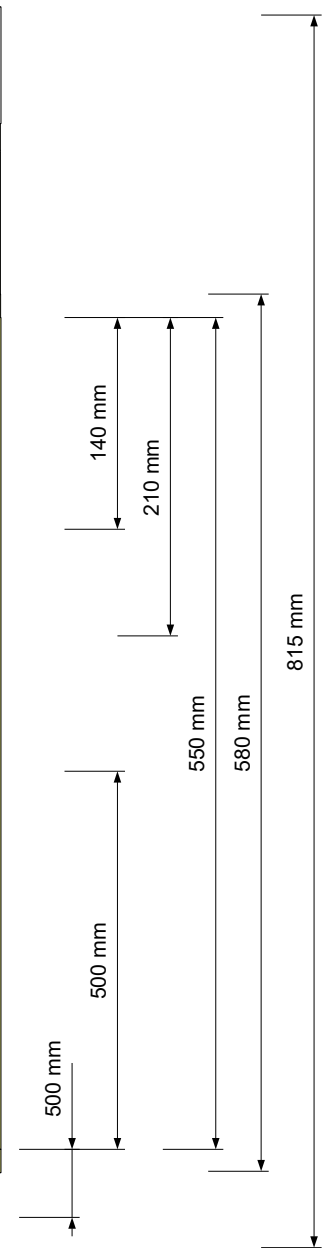
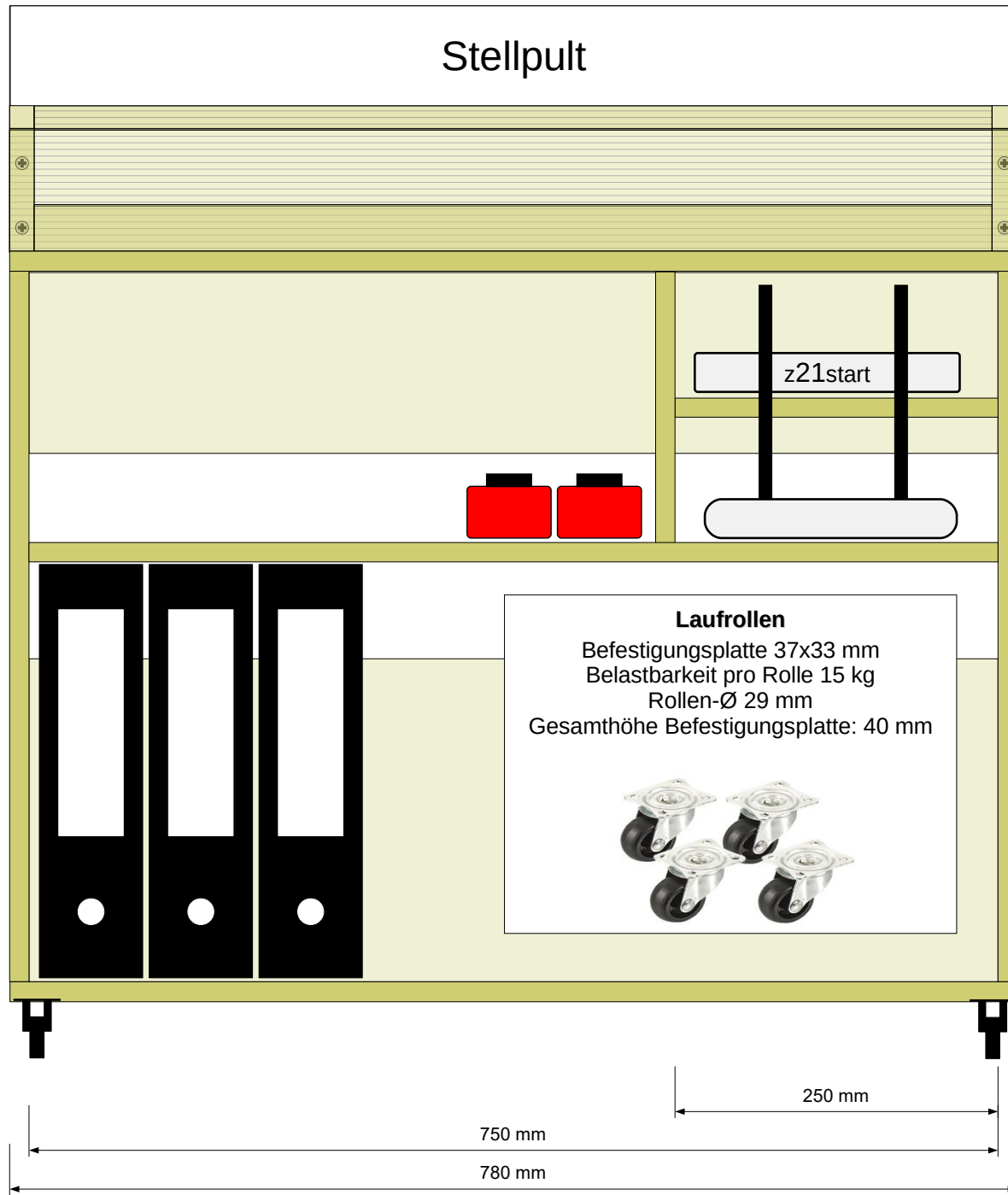

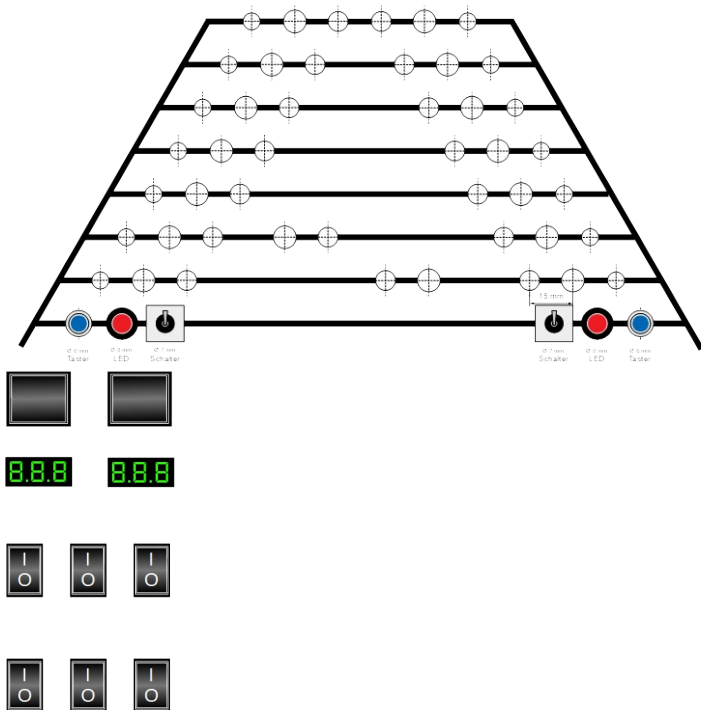

Projekt	Platte 2		Platte 3	
	Platte 1		Platte 4	
	Stellpult			
	Platte 5			
	Projekt			
Projekt		TT-Modelleisenbahn		
Name		Stellpult Seite 9		
Grundmaße:		Gesamt 780 mm x 350 mm Höhe 110 x 185 mm		
Bemerkung		Gesamtplatz für Stellwerk		
Baubeginn	09. März 2018	Bauende	09. März 2018	

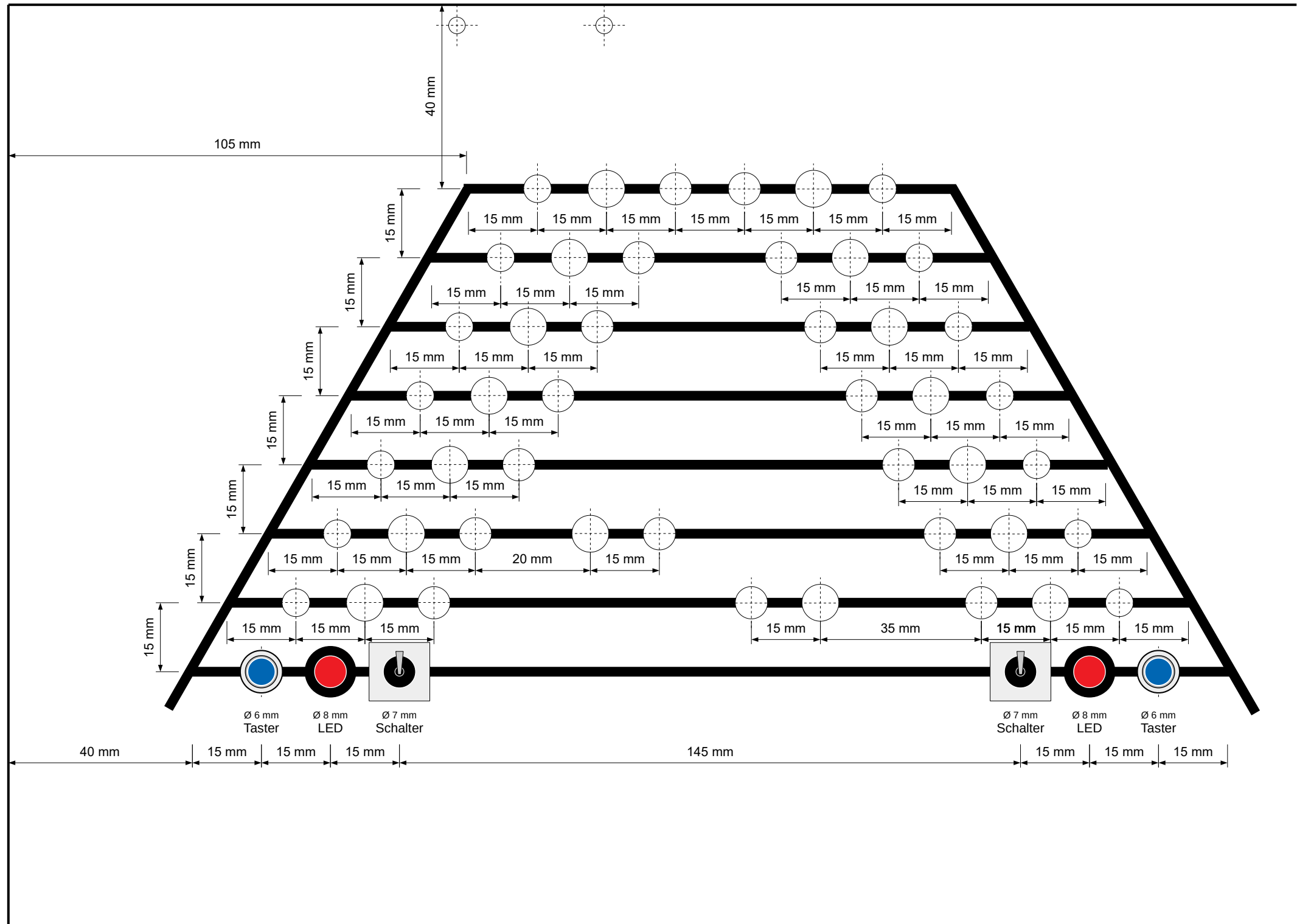

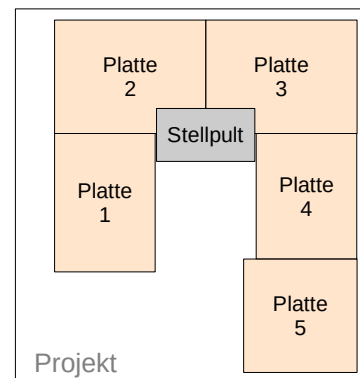
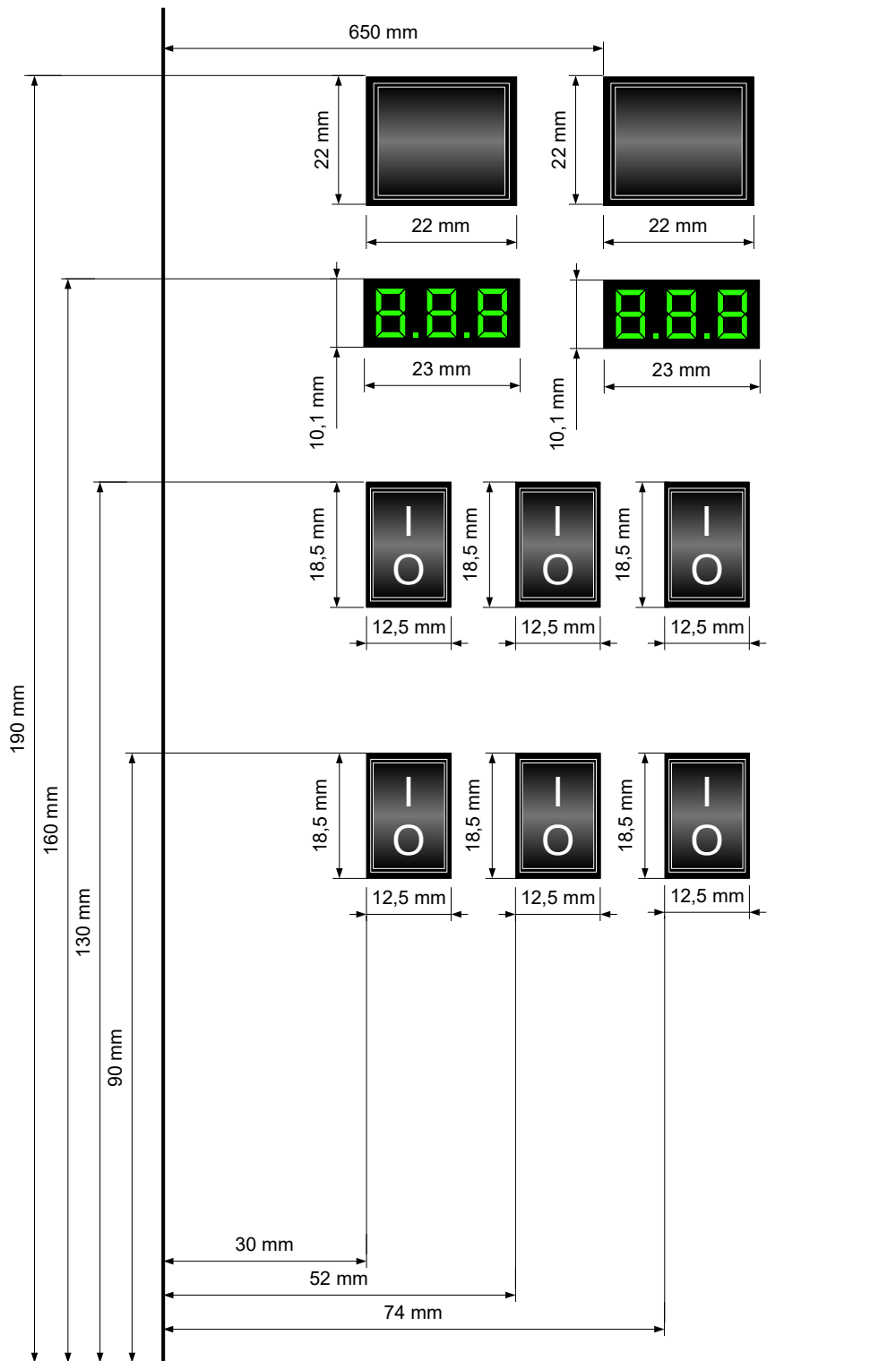

Projekt	TT-Modelleisenbahn		
Name	Stellpult Seite 11		
Bemerkung	Grundmaße:	Gesamt	780 mm x 350 mm
		Höhe	110 x 185 mm
	Gesamtplatz für Stellwerk		
Baubeginn	09. März 2018	Bauende	09. März 2018

Projekt

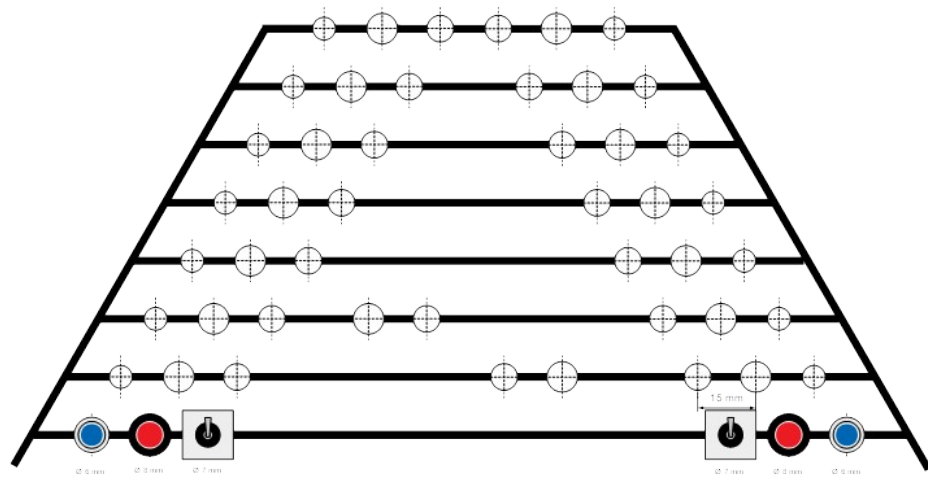

Ø 6 mm
Taster

Ø 3 mm
LED

Ø 15 mm
Schalter

Ø 7 mm
Schalter

Ø 3 mm
LED

Ø 6 mm
Taster



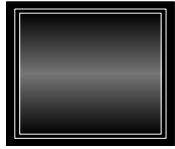
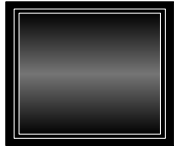

8.8.8

8.8.8



8.8.8

8.8.8



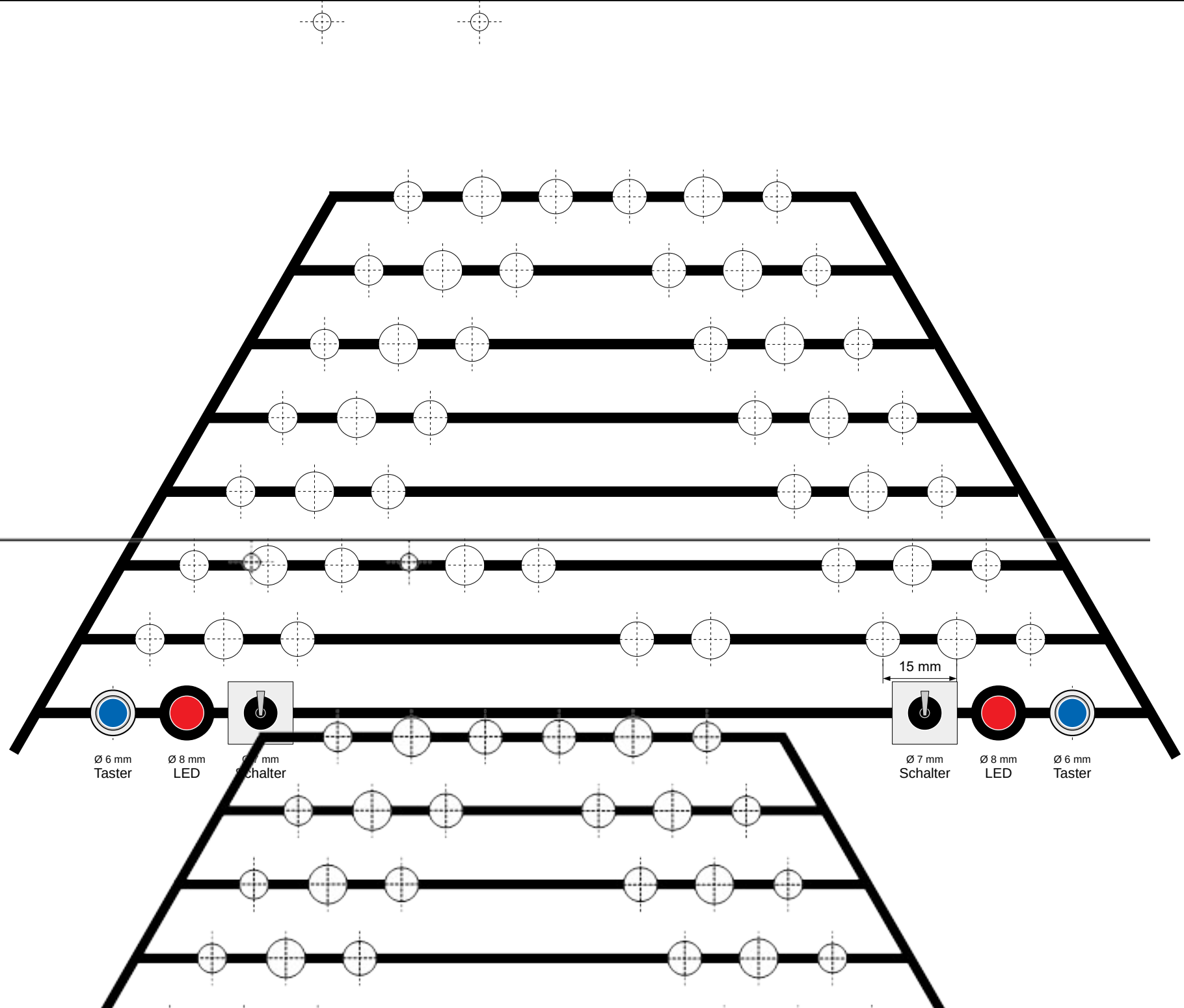

Ø 6 mm
Taster

Ø 8 mm
LED

Ø 7 mm
Schalter

Ø 7 mm
Schalter

Ø 8 mm
LED

Ø 6 mm
Taster

15 mm

Schattenbahnhof

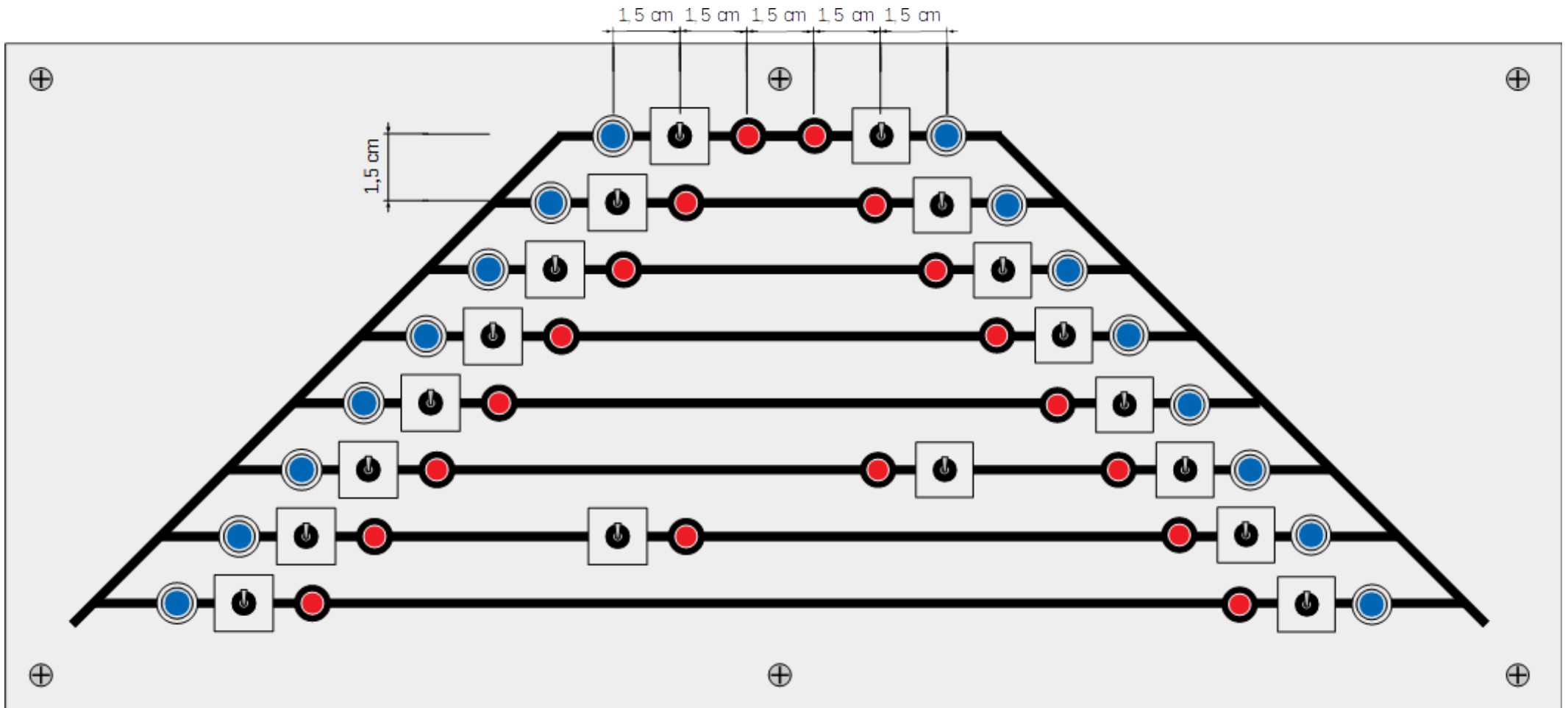

	Projekt	TT-Modelleisenbahn	
	Name	Stellpult Seite 11	
	Grundmaße:	Gesamt	780 mm x 350 mm
	Höhe		110 x 185 mm
	Bemerkung	Schattenbahnhof	
Baubeginn	09. März 2018	Bauende	09. März 2018